



Features:

- AC input voltage range selected by switch
- Small volume, low weight, high efficiency
- Protections : short circuit/over load/over voltage/over temp
- DC fan forced air cooling
- Built-in fan speed control
- LED indicator for power on
- 100% full load burn-in test
- 2 Years warranty



Dimension : 199 × 99 × 48mm

SPECIFICATION

Model		HS-350-5	HS-350-12	HS-350-15	HS-350-24
Output	DC voltage	5V	12V	15V	24V
	Voltage tolerance	± 1%	± 1%	± 1%	± 1%
	Rated current	50A	29A	23A	14.6A
	Current range	0 ~ 50A	0 ~ 29A	0 ~ 23A	0 ~ 14.6A
	Rated power	250W	348W	345W	350.4W
	Ripple&noise	150mVp-p	150mVp-p	150mVp-p	200mVp-p
	DC voltage ADJ. range	± 10%	± 10%	± 10%	± 10%
	Setup, rise, hold up time	1000ms,100ms,30ms/230VAC.			
Input	Voltage range	90 ~ 132VAC/180 ~ 264VAC(Selected by switch) 47 ~ 63Hz, 255 ~ 373VDC			
	AC current	6.5A/115V 4A/230VAC			
	Efficiency	80%	82%	82%	84%
	Inrush current	Cold start 25A/115V 50A/230VAC			
	leakage current	< 3.5mA/240VAC			
Protection	Overload	Rated output power110% ~ 135%Start overload protection			
		Protection type: hiccup mode, auto-recovery after fault condition is removed			
	Over voltage	Rated output power115% ~ 135%Start overload protection			
Protection type: hiccup mode, auto-recovery after fault condition is removed					
Over temperature	≥85°C ± 5°C(TSW1detect on heatsink of power transistor)				
	Protection mode: cutoff output, auto-recovery after temperature become normal				
Environment	Working temp, humidity	-20°C ~ +60°C;20% ~ 90%RH(Please refer to “derating curve”)			
	Storage temp, humidity	-40°C ~ +85°C;10% ~ 95%RH Non-condensing			
	Withstand vibration	10 ~ 500Hz, 5G 10min./1Cycle, Period for 60min, Each axes			
Safety	Withstand voltage	I/P-O/P: 1.5KVAC I/P-FG: 1.5KVAC O/P-FG: 0.5KVAC			
	Isolation resistance	I/P-O/P; I/P-FG,O/P-FG: 100M Ohms/500VDC			
Fit standard	Safety standard	Compliance to UL 62368-1,TUV 62368-1,EN 62368-1			
	EMC Standard	Compliance to EN 55032, CLASSA			
Others	Dimension	199*99*48mm (L*W*H)			
	Weight	0.80kg/24pcs/20kg/1.20CUFT			

Note: 1. All parameters NOT specially mentioned are measured at 230VAC input, rated load and 25°C of ambient temperature.
 2. Ripple & noise are measured at 20MHz of bandwidth by using a 12" twisted pair-wire terminated with a 0.1uf & 47uf parallel capacitor.
 3. Tolerance : includes set up tolerance, line regulation and load regulation.

Mechanical specification

Unit:mm

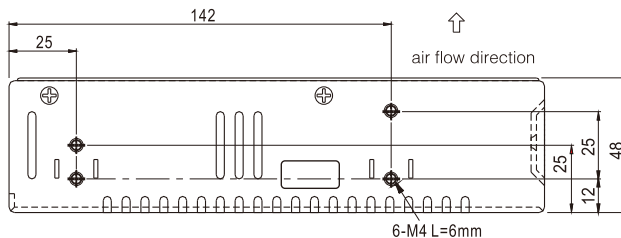
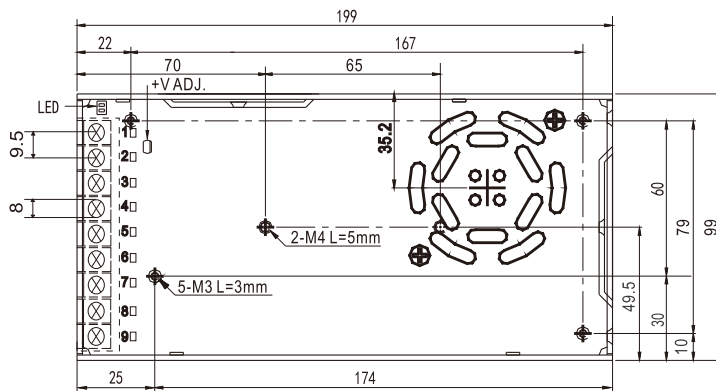

Terminal Pin No.Assignment

Pin No.	Assignment	Pin No.	Assignment
8	AC/L	4 ~ 6	DC OUTPUT -V
9	AC/N	1 ~ 3	DC OUTPUT +V
7	FG \perp		

Block diagram

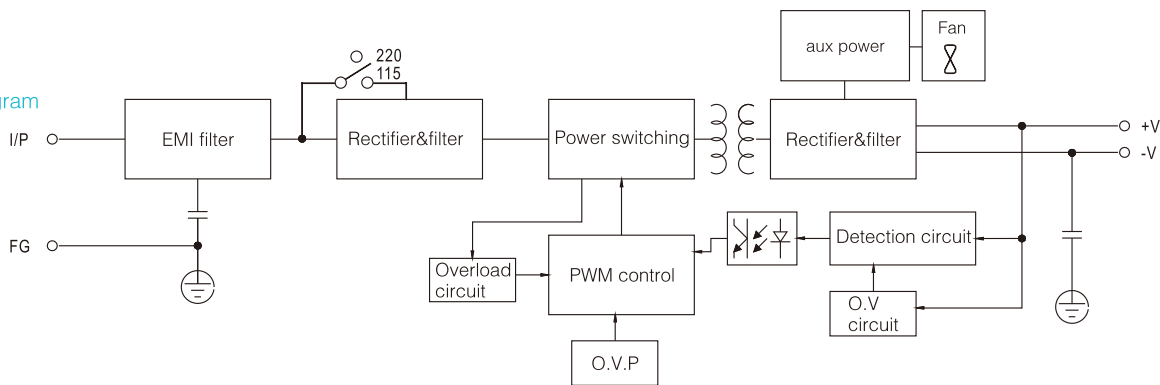

Derating curve

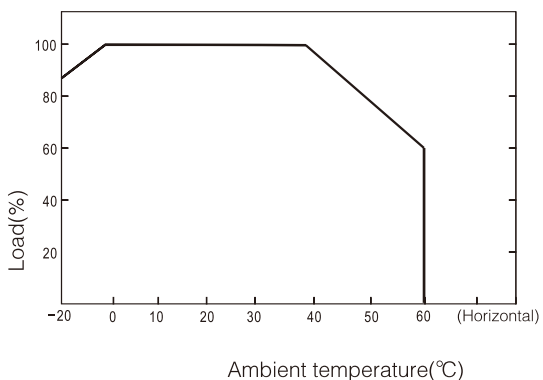

Static characteristic

